

AGITADOR TXR-5/55

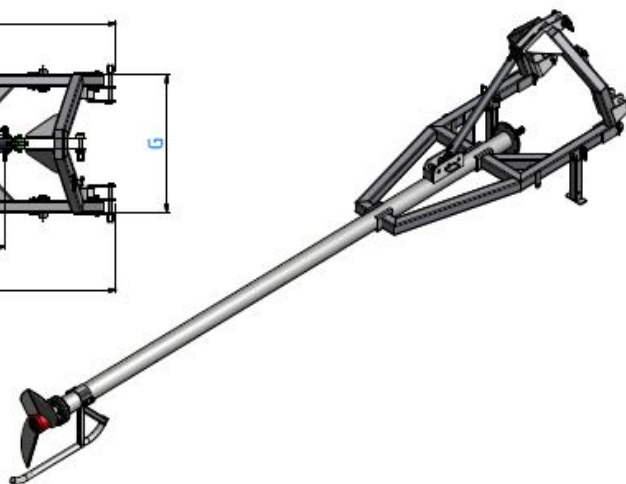
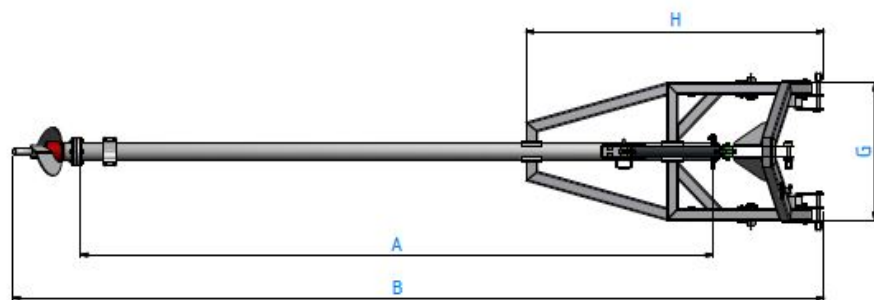
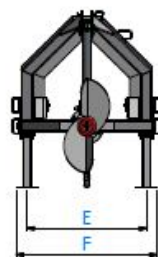

CARACTERÍSTICAS GENERALES

- Estructura de acero al carbono galvanizado.
- Peso: 306 Kg.
- Potencia Tractor : 55 CV
- Velocidad de giro: 500 rpm
- Mida eje cardán: 1-3/8(6)
- Enchufe rápido de G-1/2"

Modelo	A	B	C	D	E	F	G	H	I
TXR-5/55	4500	5773	457.5	1193	850	1000	930	2118	640